

CAD-00000657B

Spaza® Dispenser Bracket System

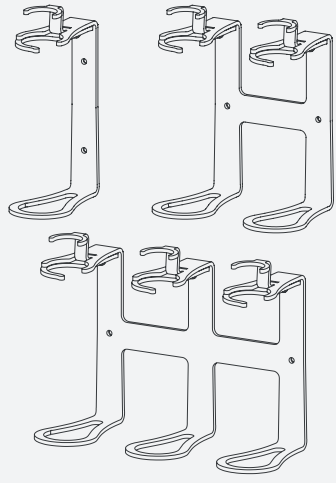

This instruction is designed for use with all products that are delivered with pre-applied tape, including lockable and non-lockable brackets in single, double, and triple versions.

INCLUDED ITEMS

- Spaza key
- Cover plug
- Pre-applied tape ^A
- Glue ^B
- Isopropanol wipe ^{A,B}
- Universal wall anchor ^{A,B,C}
- Screw 4x40mm PZ2 ^{A,B,C}

^A Only for tape method
^B Only for glue method
^C Only for screw method

REQUIRED ITEMS

- Measure
- Level
- Pen
- Primer ^{A,B} (optional)
- Glue gun for 290ml cartridges ^B
- Power drill ^C
- Drill bit 6mm (1/4") ^C
- Screw bit PZ2 ^C

^A Only for tape method
^B Only for glue method
^C Only for screw method

PRE-INSTALLATION PREPARATIONS ^{A,B,C}

Because Spaza cannot anticipate all the different possible surfaces or possible contaminants that may exist in the contact surface, it is imperative that the user conduct an evaluation to determine the suitability of surface preparations procedures, and any other processes that may have an influence on the bonded parts.

Before installing our products, we recommend conducting a test installation in a designated room to assess functionality and compatibility.

Visit spaza.se/installation-maintenance/ for comprehensive best practices, tutorials on contact surfaces and method selection for installing your Spaza bracket system.

Need assistance? Contact aftersales@spaza.se or call +46735740233 for advice on preparations and installation.

IMPORTANT INFORMATION, TAPE METHOD ^A

Surface Preparations - The wall surface must be flat, clean, and dry. In case of a surface promotor needed consult a local supplier or distributor to determine which of the available primers and surface promotors are most suitable in your region.

Contact - Bond strength is dependent upon the amount of adhesive-to-surface contact developed. Firm application pressure in 60 seconds develops better adhesive contact and helps improve bond strength. The bracket should experience at least 1 kg/cm² in pressure.

Wait - After application, the bond strength will increase as the adhesive flows onto the surface. At room temperature, approximately 90% will be achieved after 24 hours and 100% after 72 hours. Using primer will shorten these time intervals.

A. TAPE METHOD

1. Measure 120 cm (48") from floor to top of holder, and mark position of contact surface with pencil or piece of masking tape.*

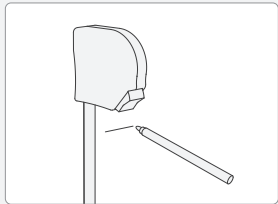

2. Clean contact surface with isopropanol alcohol (IPA), let dry thoroughly prior to installation. Applying a primer will improve initial and ultimate adhesion to many materials.

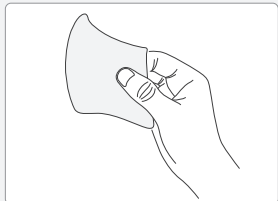

3. Peel of backing of adhesive strip on bracket, do not touch any of the adhesive tape or wall surface.

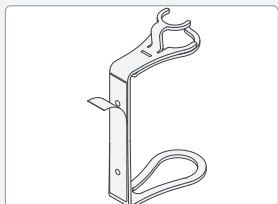

4. Aim the holder to the wall in level. Press entire holder firmly against the wall for 60 seconds to ensure holder has adhered to surface.

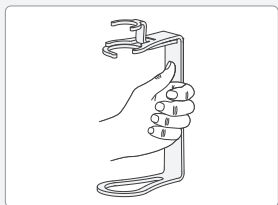

5. Place cover plugs in holder and leave on the wall for at least 24 hours before use. Read important information for additional information.

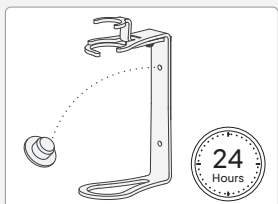

6. Place the Spaza key in the key slot. Move the hook aside, place the bottle and swing back the hook around the cap.

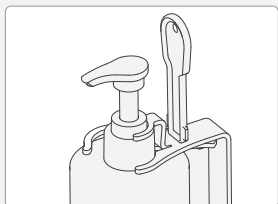

B. GLUE METHOD

1. Measure 120 cm (48") from floor to top of bracket, and mark position of contact surface with pencil or piece of masking tape.*

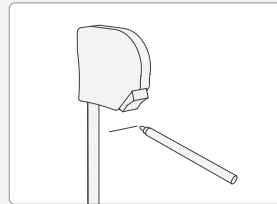

2. Clean contact surface with isopropanol alcohol (IPA), let dry thoroughly prior to installation. Applying a primer will improve initial and ultimate adhesion to many materials.

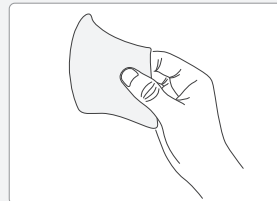

3. Install cover plugs in the bracket screw holes. Apply the glue to the back side of bracket.

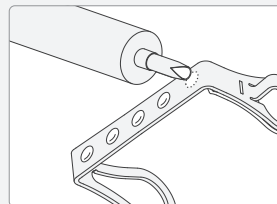

4. Aim the bracket to the wall in level and press to ensure glue has spread over the contact surface.

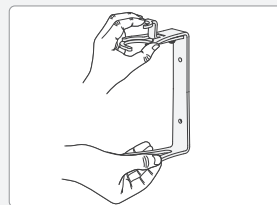

5. Leave bracket on the wall for at least 12 hours before use.

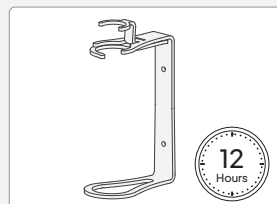

6. Place the Spaza key in the key slot. Move the hook aside, place the bottle and swing back the hook around the cap.

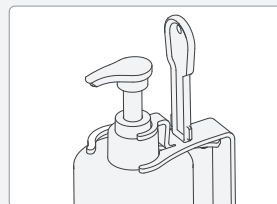

C. SCREW METHOD

1. Measure 48 inches (120 cm) from floor to top of bracket, and mark position of each drill hole with pencil.*

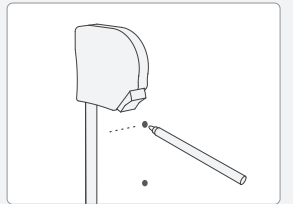

2. Drill holes, drill depth minimum 40 mm. Insert wall anchors into hole by carefully tapping with hammer.

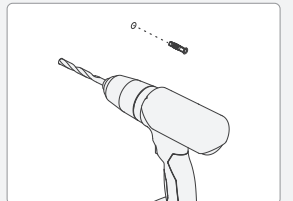

3. Clean contact surface with isopropanol alcohol (IPA), let dry thoroughly prior to installation.

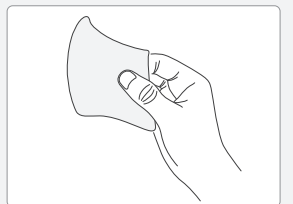

4. Peel of backing of adhesive strip on bracket, do not touch any of the adhesive tape or wall surface.

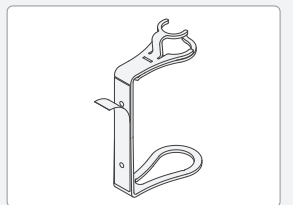

5. Aim the bracket towards the drill holes, press entire bracket to wall and ensure tape has adhered to surface. Install with included screws through the bracket into the wall anchors.

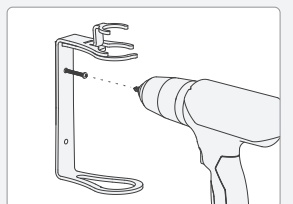

6. Place the Spaza key in the key slot. Move the hook aside, place the bottle and swing back the hook around the cap.

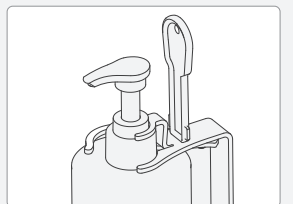

*For ADA (Americans with Disabilities Act) designated rooms – we recommend installation at 41 inches (104 cm) for accessibility.